

POWERFLEX®

PART NUMBER

PFF19-2202

DESCRIPTION

FRONT WISHBONE REAR BUSH

INSTALLATION GUIDE

Contents (parts per pack):

- | | |
|-------------------------|-----------------------------|
| 2 x Polyurethane Bushes | 1 x PTFE/Silicone Grease |
| 2 x Steel Outer Shells | 2 x Stainless Steel Sleeves |

Please read the complete fitting instructions and check package components before fitment. These fitting instructions are to be used as a guide and in conjunction with workshop manual.

It is recommended that:

- all work to be carried out by a licensed technician;
- all safety precautions adhered to;
- wheel alignment to be checked and adjusted as required after any suspension work.
- All fasteners must be tensioned to manufacturer's torque settings.

Fitting Instructions:

1. Remove the original bush including its outer shell from the arm.
2. Clean any dirt or burrs from the bore in the arm. Remove any sharp edges with a rounded file.
3. Press the plated steel outer shell into the top side of the arm, until sitting flush to the face of the arm.
4. Apply some washing up liquid to the bore of the shell and press the polyurethane bush in until fully through the arm. The orientation is marked on the bush.

Note: On the Mk7, the bush fits from the bottom of the wishbone. On the Mk8, the bush fits from the top of the wishbone.

Tip: To aid fitment, try pressing the bush in at a slight angle so that one part of the lip is already in the bore of the shell, and when steady pressure is applied, the rest of the lip should follow.

5. Apply the supplied grease to the bore of the bush and inner sleeve.
6. Press the stainless-steel sleeve into the bush.
7. Re-fit the arm to the vehicle and tension all hardware to manufacturers recommended torque settings.



Mk8



Mk7



Mk7

Mk8

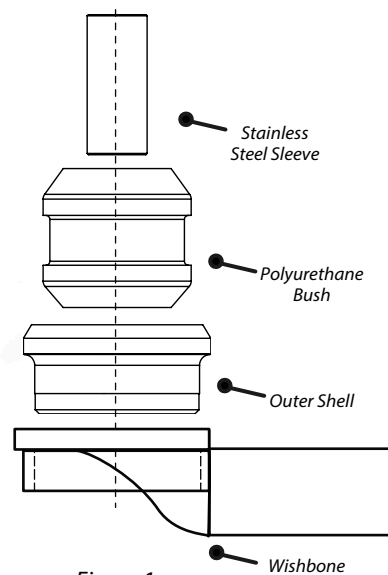

Figure 1

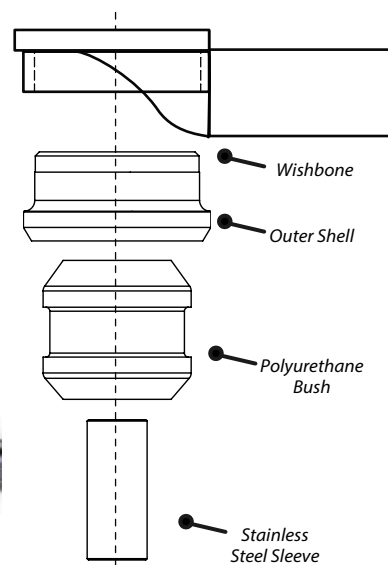

Figure 2